

NO.	DATE	REVISION DESCRIPTION	SIGN	APPD
①	-	-	-	-
②	-	-	-	-

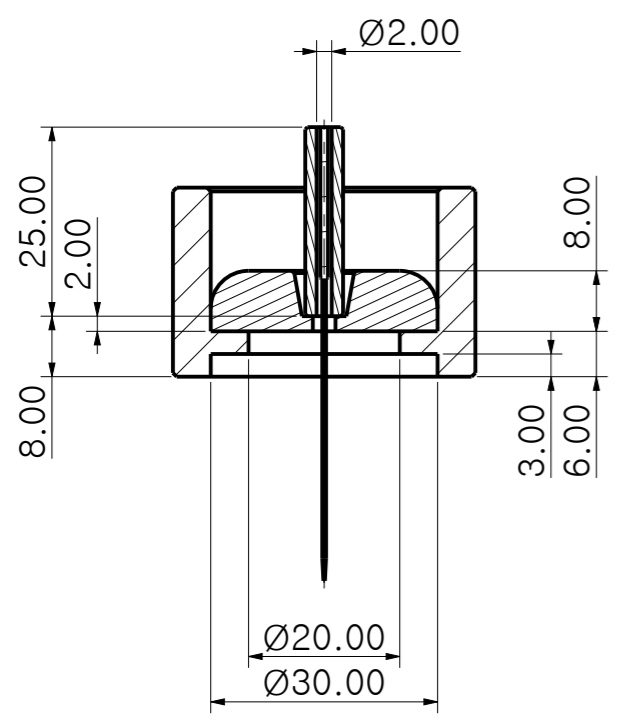
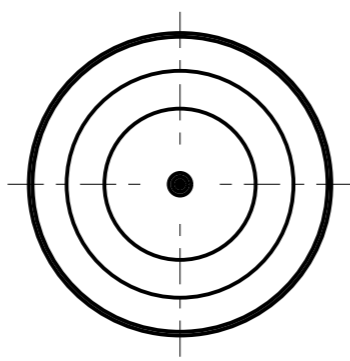
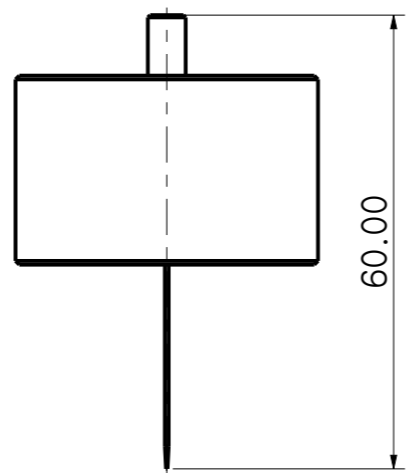
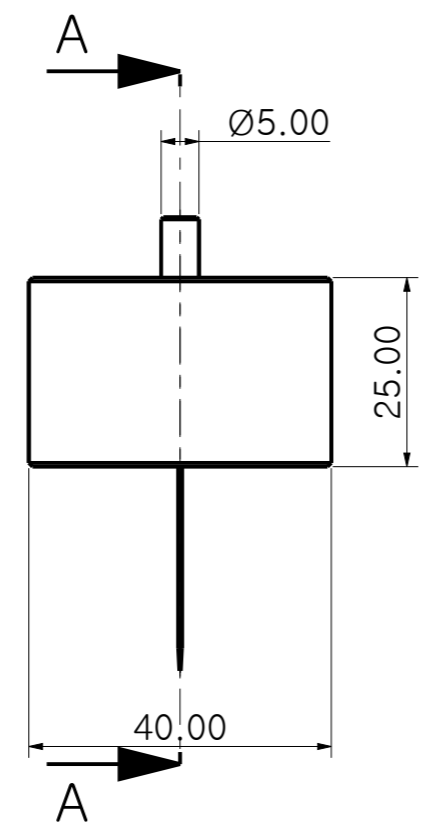
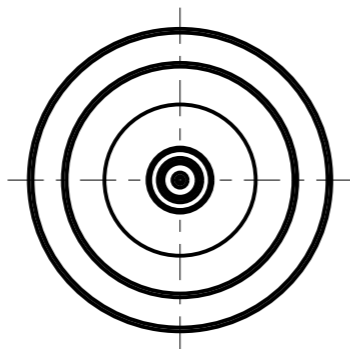

SECTION A-A

5	PART	NEEDLE	1			
4	PART	MOXA	1			
3	PART	MOXA-SUPPORT	1			
2	PART	MOXA-CASE	1			
1	SKELETON MODEL	ASM_MOXA-CASE_SKEL	1			
NO	PART No.	DESCRIPTION	Q'TY	MATERIAL	FINISH	REMARKS

SURFACE ROUGHNESS

Symbol	W	X	Y	Z	Value	Grade
~	✓	-	-	-	-	-
▽	✓	25	-	-	100S	-
▽▽	✓	6.3	-	-	25S	-
▽▽▽	✓	1.6	-	-	6.3S	-
▽▽▽▽	✓	0.2	-	-	0.8S	-

UNLESS OTHERWISE SPECIFIED, DIMENSIONS ARE IN MILLIMETERS AND TOLERANCES ARE AS FOLLOWS

Dimension ratings	Precision	Normal grade	Geochingjeup
0.5-3	±0.05	±0.1	-
3-6	±0.10	±0.2	±0.2
6-30	±0.15	±0.3	±0.5
30-120	±0.20	±0.5	±0.8
120-315	±0.30	±0.8	±1.2
315-1000	±0.50	±1.2	±2.0
1000-2000	±0.50	±1.2	±3.0

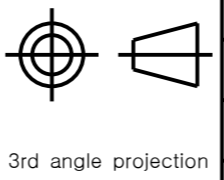

3rd angle projection

TOLERANCE		FINISH	Q'ty	MATERIAL	PD SOLUTION
DECIMAL	ANGLE	SHEET	SCALE	MODEL	
.x ±0.1 .xx ±0.05	±0.5°	1 / 1	1/1		
UNIT	REMARK	DESIGNED	VER.	PART NAME	
mm	-	KST	-	ASM_MOXA-CASE	
		CHECKED	WEIGHT	DWG NO.	
		APPROVED	g	PART NO.	
			DATE		
			2020.10.26		

A3